

HINGE TYPE CLAMP - BOLT ROTATING patent

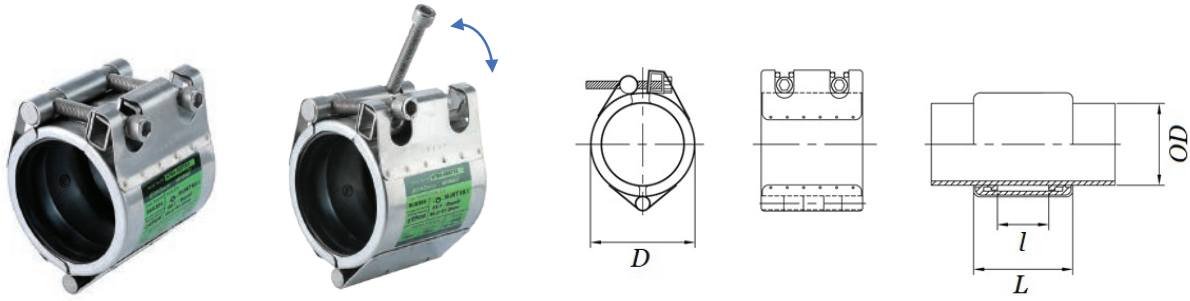

This is the improved version of MJH. You can lock up clamp by simply ① swiveling bolt, the end of which is already inserted into bar nut, ② putting it onto bar washer, and ③ bolting up. The process is very simple and reduces working time compared to MJH or other types.

■ MJHT 15A~600A

Item No.	Pipe OD			D (mm)	Clamping Range (mm)	Thickness (mm)	Working Pressure (bar)		MJHT			
	ND	inch	actual (mm)				Ship	Industry	Length (mm)		Torque (Nm)	Bolt (M)
									L	l		
01	15A	1/2	21.7	34.8	21.0 ~ 23.0	0.8	16	32	60	28	7	6
05	20A	3/4	25.0	38.1	24.0 ~ 26.0	0.8	16	32	60	28	7	8
04			27.2	40.3	26.0 ~ 28.0	0.8	16	32	60	28	7	8
06			28.2	41.3	26.4 ~ 29.0	0.8	16	32	60	28	7	8
08	25A	1	30.0	43.1	29.0 ~ 31.0	0.8	16	32	60	28	7	8
09			32.0	45.1	31.0 ~ 33.0	0.8	16	32	60	28	7	8
07			34.0	47.1	33.0 ~ 35.0	0.8	16	32	60	28	7	8
N9			35.0	48.1	34.0 ~ 36.0	0.8	16	32	60	28	7	8
10	32A	1 1/4	38.0	51.1	37.0 ~ 39.0	0.8	16	32	60	28	7	8
13			40.9	54.0	39.5 ~ 41.5	0.8	16	32	60	28	7	8
11			42.7	55.8	42.0 ~ 44.0	0.8	16	32	60	28	7	8
12			44.5	57.6	44.0 ~ 46.0	0.8	16	32	60	28	7	8
15	40A	1 1/2	48.6	61.7	47.5 ~ 49.5	0.8	16	32	60	28	7	8
17			50.8	63.9	49.2 ~ 51.5	0.8	16	32	60	28	7	8
18	50A	2	54.0	70.0	53.0 ~ 55.0	1.0	16	32	80	44	12	8
19			57.0	73.0	56.0 ~ 58.0	1.0	16	32	80	44	12	8
20			60.5	76.5	59.0 ~ 61.5	1.0	16	32	80	44	12	8
21			63.0	79.0	62.0 ~ 64.0	1.0	16	32	80	44	12	8
26	65A	2 1/2	66.7	82.7	65.4 ~ 68.3	1.0	14	28	80	44	12	8
25			69.0	85.0	68.5 ~ 71.0	1.0	14	28	80	44	12	8
23			73.0	89.0	72.5 ~ 75.5	1.0	14	28	80	44	12	8
24			76.3	92.3	75.0 ~ 78.0	1.0	14	28	80	44	12	8
30	80A	3	79.9	99.9	78.8 ~ 82.0	1.0	14	28	110	59	30	12
27			84.0	104.0	82.5 ~ 85.5	1.0	14	28	110	59	30	12
28			89.1	109.1	88.0 ~ 91.0	1.0	14	28	110	59	30	12
32	90A	3 1/2	101.6	121.6	100.0 ~ 103.0	1.0	14	28	110	59	30	12
34	100A	4	104.0	124.0	102.0 ~ 105.0	1.0	14	28	110	59	40	12
37			106.3	126.3	105.0 ~ 107.5	1.0	14	28	110	59	40	12
35			108.0	128.0	106.0 ~ 109.0	1.0	14	28	110	59	40	12
38			110.0	130.0	108.5 ~ 111.5	1.0	14	28	110	59	40	12
36			114.3	134.3	113.0 ~ 116.0	1.0	14	28	110	59	40	12
Q2			125.0	146.5	123.0 ~ 126.0	1.5	14	28	111	59	40	12
42	125A	5	127.0	148.5	125.0 ~ 129.0	1.5	14	28	111	59	40	12
43			129.0	150.5	127.5 ~ 130.0	1.5	14	28	111	59	40	12
S4			130.2	151.7	129.0 ~ 131.0	1.5	14	28	111	59	40	12
39			133.0	154.5	131.0 ~ 135.0	1.5	14	28	111	59	40	12
40			139.8	161.3	138.0 ~ 142.0	1.5	14	28	111	59	40	12
41			141.3	162.8	139.5 ~ 143.5	1.5	14	28	111	59	40	12

Item No.	Pipe OD			D (mm)	Clamping Range (mm)	Thickness (mm)	Working Pressure (bar)		MJHT			
	ND	inch	actual (mm)				Ship	Industry	Length (mm)		Torque (Nm)	Bolt (M)
									L	I		
49	150A	6	150.0	171.5	148.0 ~ 152.0	1.5	12	24	111	59	40	12
44			154.0	175.5	151.5 ~ 155.5	1.5	12	24	111	59	40	12
45			159.0	180.5	156.0 ~ 160.0	1.5	12	24	111	59	40	12
46			165.2	186.7	164.0 ~ 167.0	1.5	12	24	111	59	40	12
47			168.3	189.8	166.0 ~ 170.0	1.5	12	24	111	59	40	12
Q6	175A	7	180.0	201.5	178.0 ~ 182.0	1.5	10	20	111	59	45	12
54	200A	8	200.0	224.5	198.0 ~ 203.0	2.0	8	16	150	89	60	14
55			204.0	228.5	202.0 ~ 206.0	2.0	8	16	150	89	60	14
51			216.3	240.8	214.0 ~ 218.5	2.0	8	16	150	89	60	14
52			219.1	243.6	216.5 ~ 221.5	2.0	8	16	150	89	60	14
59	250A	10	254.0	278.5	251.0 ~ 257.0	2.0	8	16	150	89	60	14
56			267.4	291.9	262.0 ~ 269.0	2.0	8	16	150	89	60	14
57			273.1	297.6	270.0 ~ 276.0	2.0	8	16	150	89	60	14
66	300A	12	304.0	328.5	301.5 ~ 308.0	2.0	7	14	150	89	60	14
61			318.5	343.0	316.0 ~ 322.5	2.0	7	14	150	89	60	14
64			323.9	348.4	322.0 ~ 328.0	2.0	7	14	150	89	60	14
67	350A	14	355.6	380.1	352.0 ~ 359.5	2.0	7	14	150	89	75	14
71	400A	16	406.4	430.9	402.0 ~ 410.0	2.0	6	12	150	89	75	14
74	450A	18	457.2	481.7	453.0 ~ 460.0	2.0	6	12	150	89	90	14
77	500A	20	508.0	532.5	504.0 ~ 512.0	2.0	5	10	150	89	90	14
80	550A	22	558.8	583.3	555.0 ~ 563.0	2.0	4.6	9.2	150	89	90	14
83	600A	24	609.6	634.1	605.0 ~ 614.0	2.0	4.2	8.4	150	89	90	14

[Remarks]

D value varies depending on how much bolts are tightened.

Burst pressure \geq working pressure for ship x safety factor (4)

Burst pressure \geq working pressure for industry x safety factor (2)

MJD, MJT, MJF (Multi-Locks Type) for over ND600 (page 22~24).

MJDF (Multi-Locks Force Type) for higher pressure (page 23).

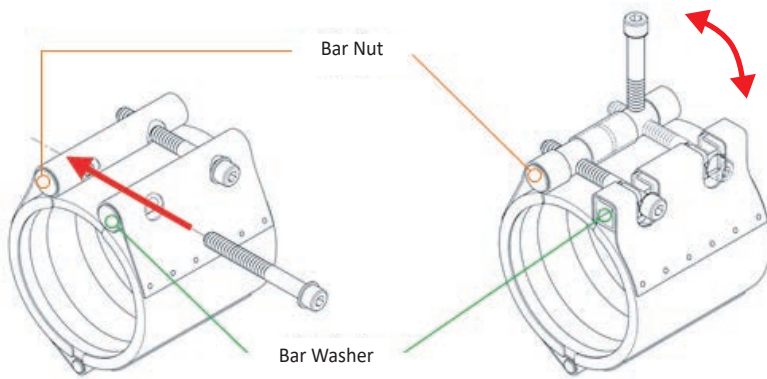

MJH (left) vs. MJHT (right)

